DIFFERENT STROKES FOR DIFFERENT FOLKS

John D'Ambrosia
Chairman, Ethernet Alliance
April 16, 2015



ethernet alliance

Regarding the Views Expressed

My Industry Involvement

- Chairman, Ethernet Alliance Board of Directors
- Chair, IEEE P802.3bs 400GbE Task Force
- Recording Secretary, IEEE 802 Executive Committee



The views I am expressing on IEEE standards and related products should NOT be considered the position, explanation, or interpretation of the Ethernet Alliance.



Per IEEE-SA Standards Board Bylaws, Dec 2013

“At lectures, symposia, seminars, or educational courses, an individual presenting information on IEEE standards shall make it clear that his or her views should be considered the personal views of that individual rather than the formal position of IEEE.”

Today's Challenges for Ethernet

- The explosion of users
 - New devices & markets
 - Apps, apps, apps
 - End-user experience driven by bandwidth
 - Multiplicative effect driving bandwidth growth
- Diversity in applications and business models

Market Diversity Examples

IEEE 802.3 HSSG - 2007

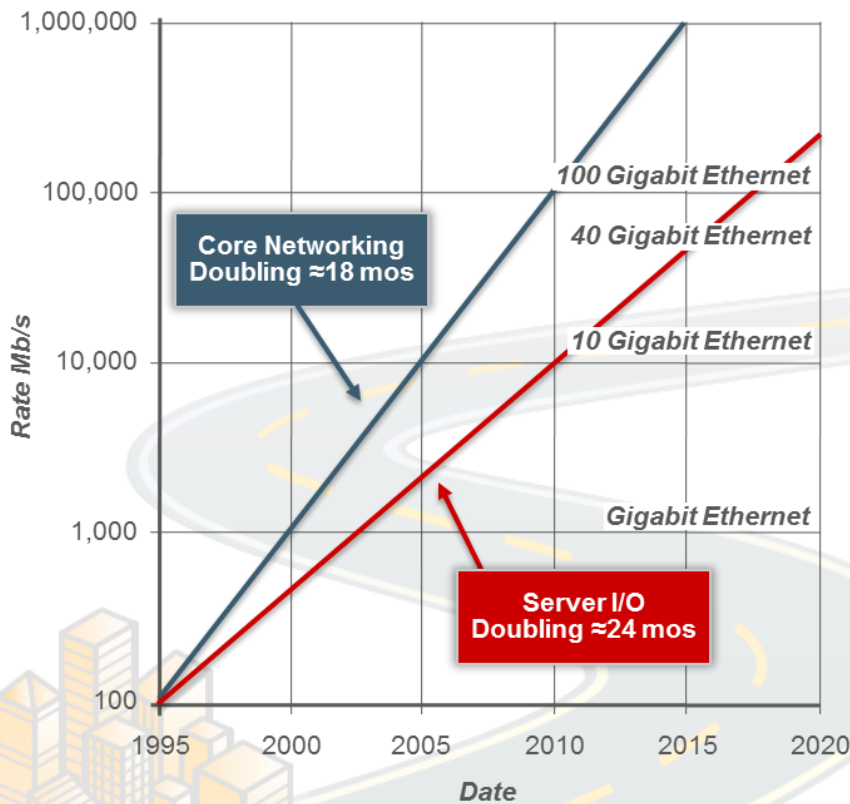

Source: http://www.ieee802.org/3/hssg/public/nov07/HSSG_Tutorial_1107.zip

IEEE 802.3 BWA - 2012

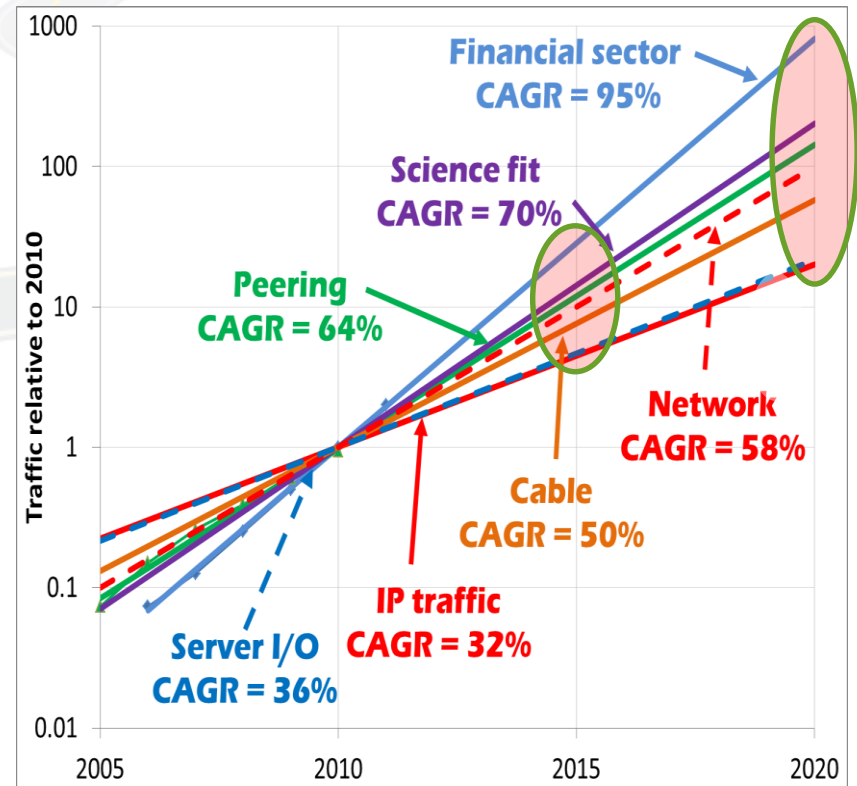

Source: http://www.ieee802.org/3/ad_hoc/bwa/BWA_Report.pdf

What's Going on?



- Market diversification
- The role of standards
- Technology
- Business models
- Ethernet is changing!
- The Appearance of Chaos!

New Rates and Target Applications

Ethernet Rate	Wireless Access Points	Servers	Networking
1 Gb/s	✓	✓	
2.5 Gb/s	✓		
5 Gb/s	✓		
10 Gb/s	✓	✓	✓
25 Gb/s		✓	
40 Gb/s		✓	✓
100 Gb/s			✓
400 Gb/s			✓

Why 2.5G / 5G BASE-T?

- From 2003 to 2014 about 70 billion meters of Cat 5e and Cat 6 cabling were sold....
- The introduction of 802.11ac for wireless access points and > GbE needs
- 90% of ports outlets (≈ 1.3 B) are Cat 5e or Cat 6
- Customers want more value from this infrastructure.



What is Behind the Wall?

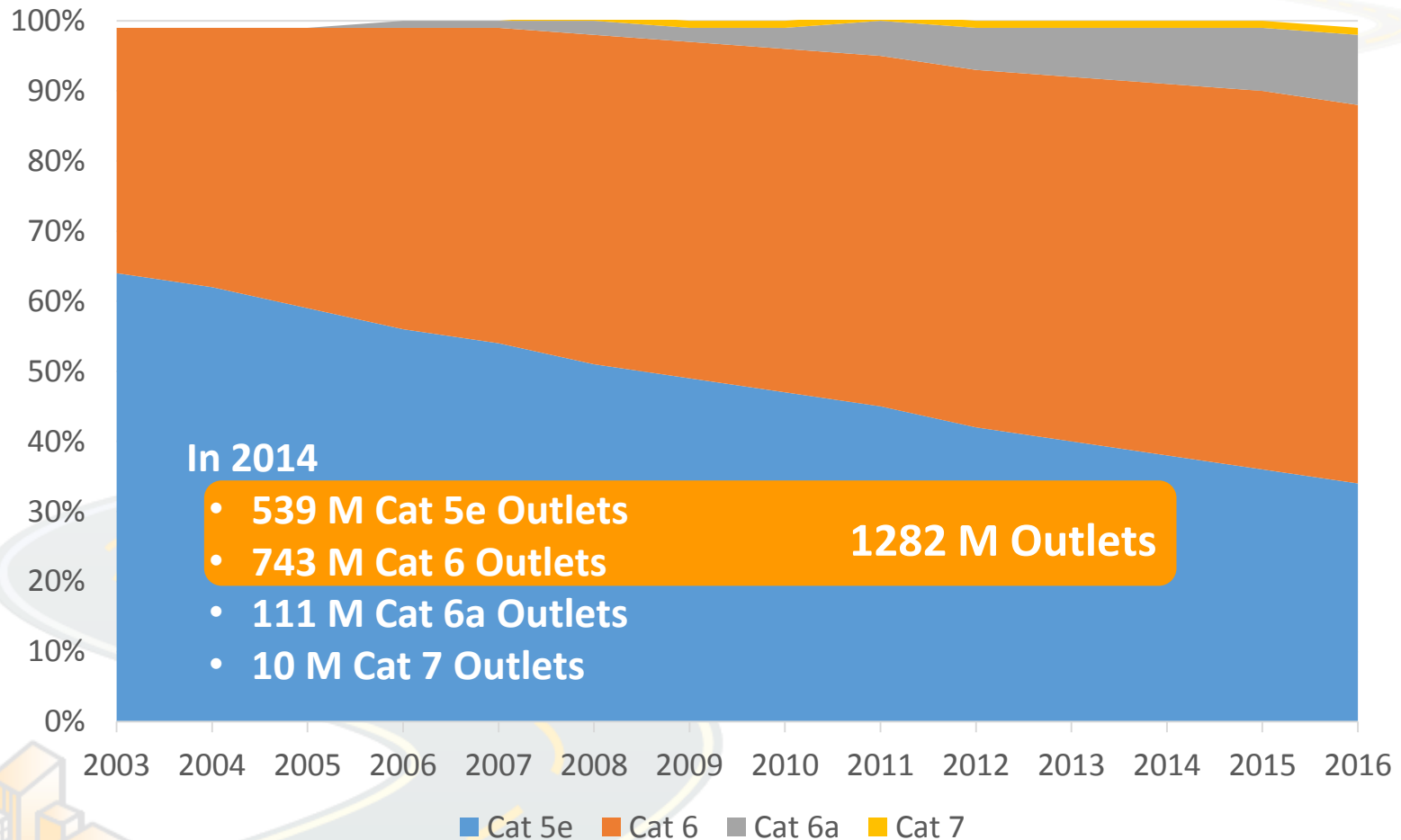

Source: NGEABT Study Group Cabling Installed Base Update (BSRIA),
http://www.ieee802.org/3/NGEBASET/public/jan15/jones_ngeabt_04c_0115.pdf

Why 25GbE Servers?



		3.2 Tb/s Switch Based on 32 QSFP Ports			# TORs for a 100K Server Data Center
Server I/O	Servers	100 GbE Uplinks	Throughput (Tb/s) per ToR Switch	Utilization (%)	
40GbE (4x10G)	28	4	1.52	47.5	3572
25GbE (Single Lane)	96	8	3.2	100	1042

Source: Ethernet Alliance, Ethernet 103: Introduction to 25Gb/s Ethernet, <https://www.brighttalk.com/webcast/6205/135253>

Benefits of 25GbE

- **Maximize Switch Throughput & Efficiency**
- **Minimize CAPEX**
 - Minimize # of ToR switches
 - Minimize # of Cables
- **Minimize OPEX**
 - Less Power
 - Less Cooling
- **Minimize Cost per Bit**
- **Technology Exists today!**



400 GIGABIT ETHERNET

THE NEXT HIGHER SPEED



ethernet alliance

www.ethernetalliance.org

Defining the 400 GbE Family Today

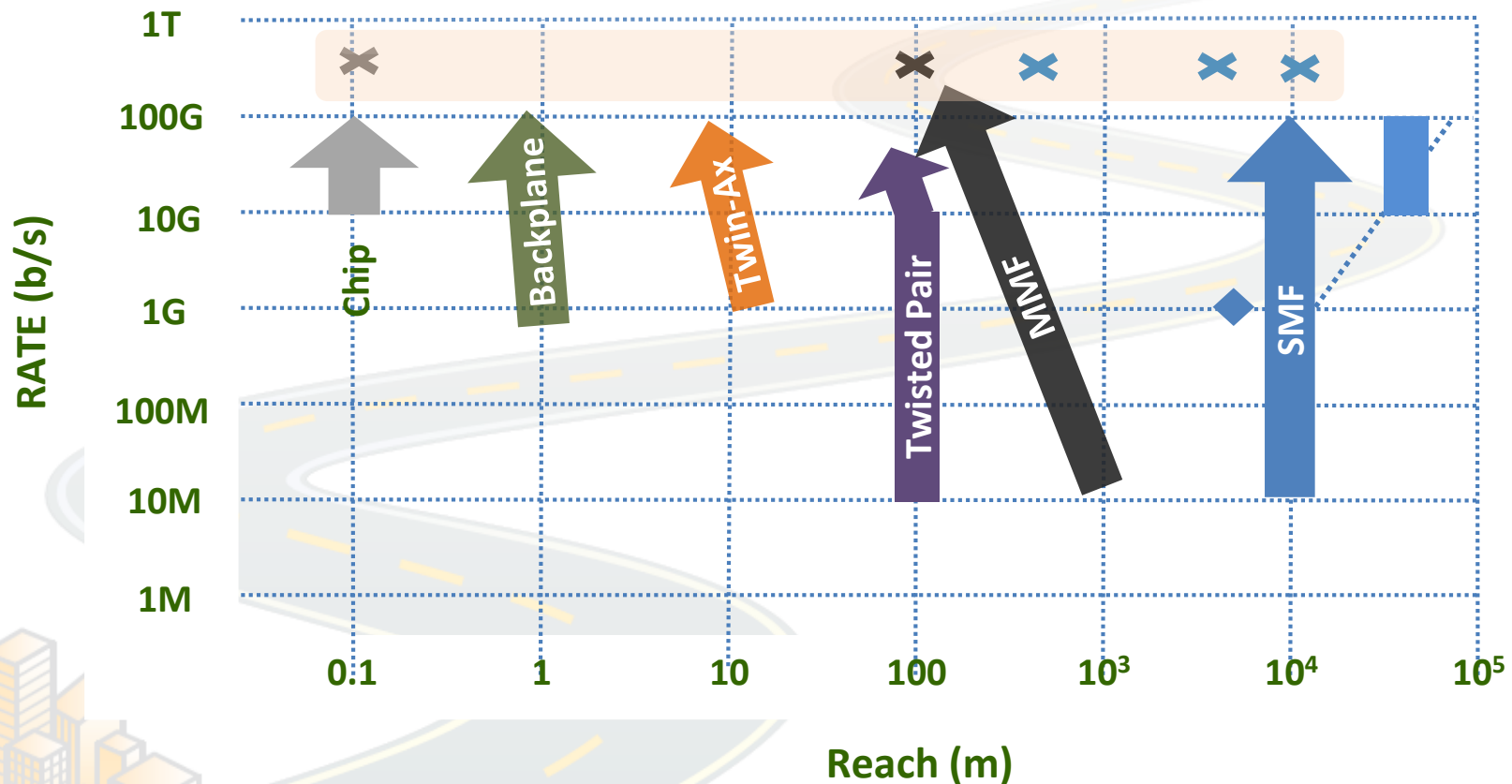

The 400GbE Architecture

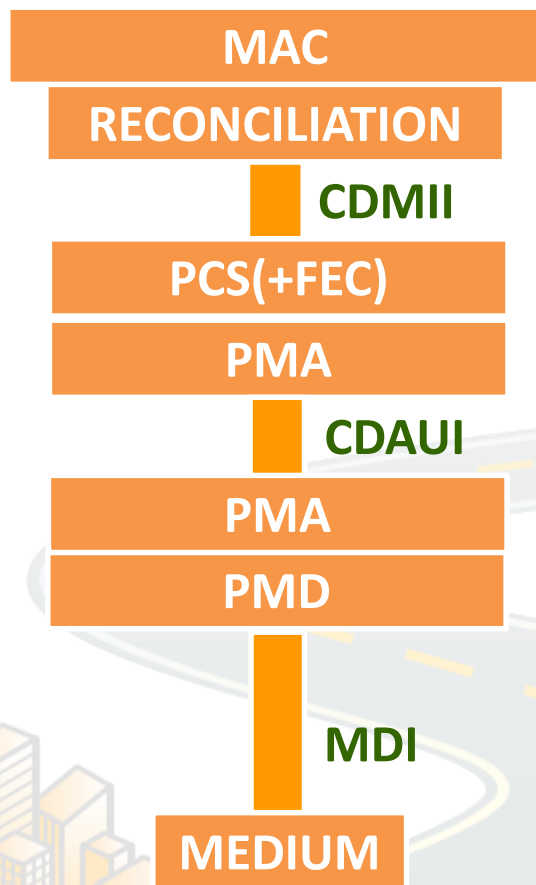

- **Goals**
 - **Flexibility**
 - **Support today's and tomorrow's 400GbE family**
 - **Interoperability between multi-generation implementations**
 - **Enable PHY innovation**
 - **Enable future PCS/FEC's**

Key Decisions

- Architecture
 - CDMII & Extender Sublayer
 - KP4 FEC (embedded in PCS)
 - Optional EEE Support
 - Appropriate OTN Support
 - Better future proofing
- Chip-to-chip (C2C) and C2M electrical interfaces
 - 16 x 25Gb/s (NRZ, based on 802.3bm)
 - 8x 50 Gb/s (PAM-4)
- 100m MMF (16 x 25G, NRZ – 16 parallel fibers, based on 802.3bm)

PAM-4 Electrical Test Data

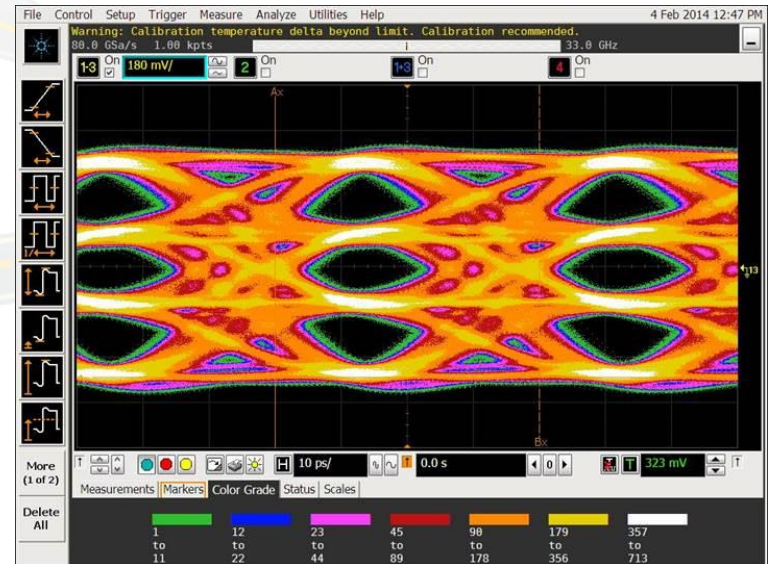

Used with permission from Adam Healey, Avago Technologies.
Measured test data presented in
http://www.ieee802.org/3/bs/public/14_11/healey_3bs_01a_1114.pdf.

400 GbE Optical Proposals

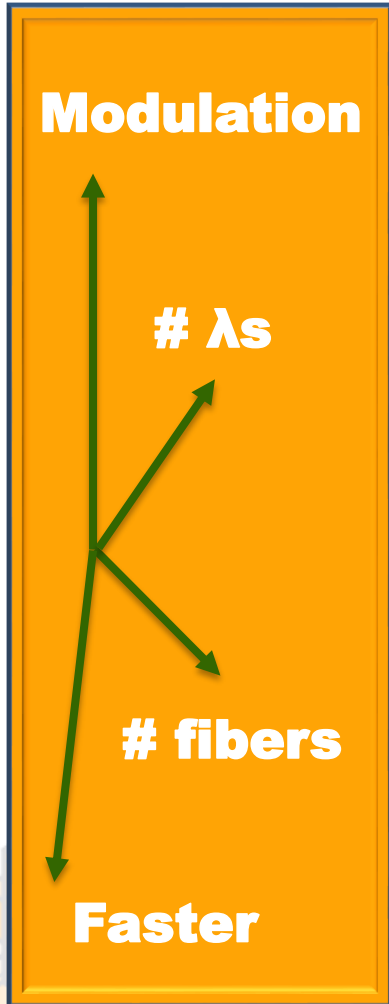

100m MMF	25G NRZ x16 Fibers				
500m SMF		2λ x 50G NRZ x4 Fibers		1λ x 100G PAM-4 x4 Fibers	
2km SMF		8λ x 50G NRZ x1 Fiber	8λ x 50G PAM-4 x1 Fiber	4λ x 100G PAM-4 x1 Fiber	
10km SMF		8λ x 50G NRZ x1 Fiber	8λ x 50G PAM-4 x1 Fiber		4λ x 100G DMT x1 Fiber

Too many hammers!

INDUSTRY TRENDS FOR HIGHER SPEEDS



ethernet alliance

www.ethernetalliance.org

Optical Modules for Ethernet

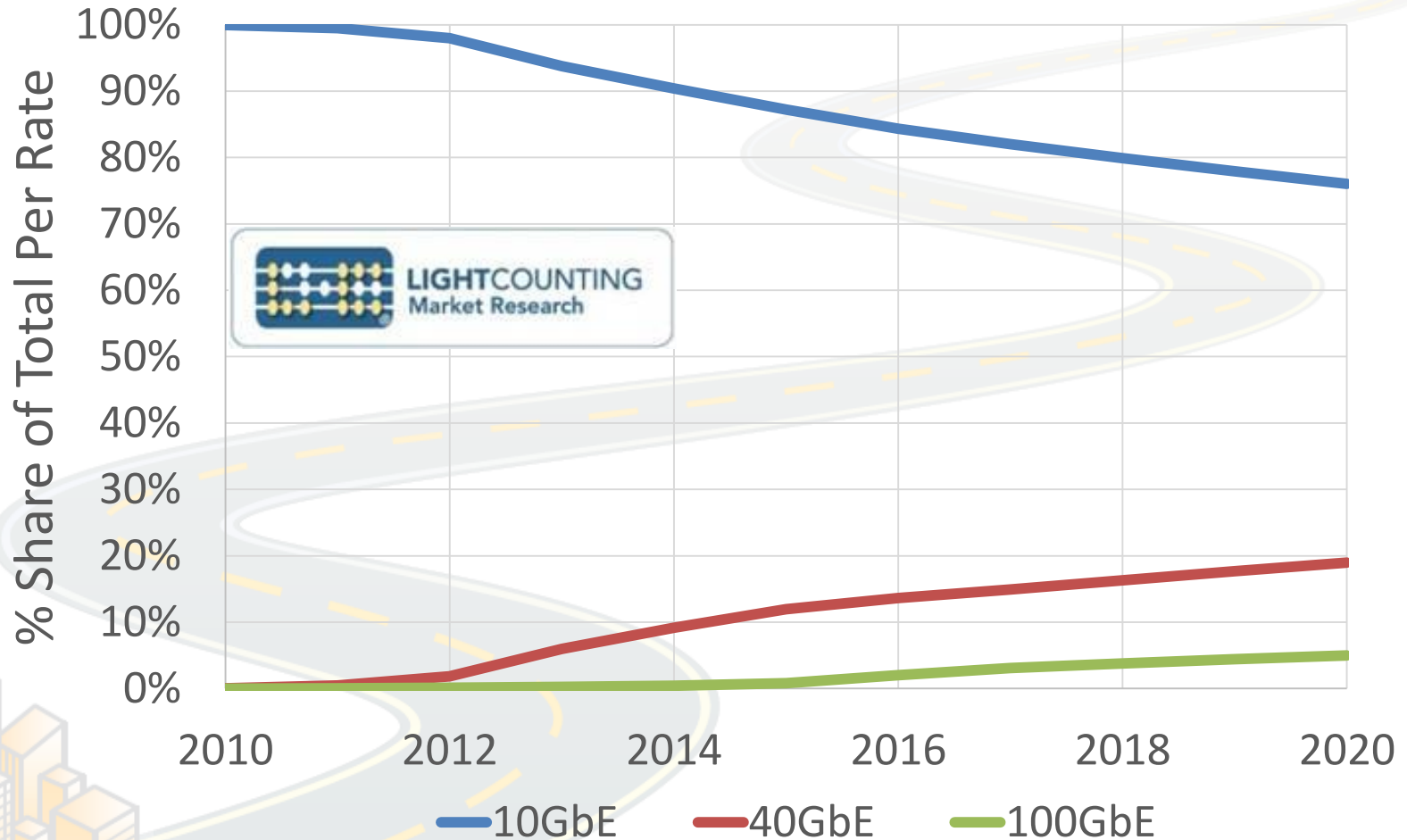

Trend #1: “Chip-to-Module”(C2M) Interfaces

- 10GbE interfaces not defined by IEEE 802.3
- IEEE 802.3ba 40GbE and 100GbE C2M interfaces, based on 10Gb/s
- IEEE 802.3bm 100GbE C2M, based on 25Gb/s
- IEEE 802.3bs 400GbE C2M, based on 25Gb/s and 50Gb/s

C2M Interfaces 10GbE, 40GbE, and 100GbE Optics

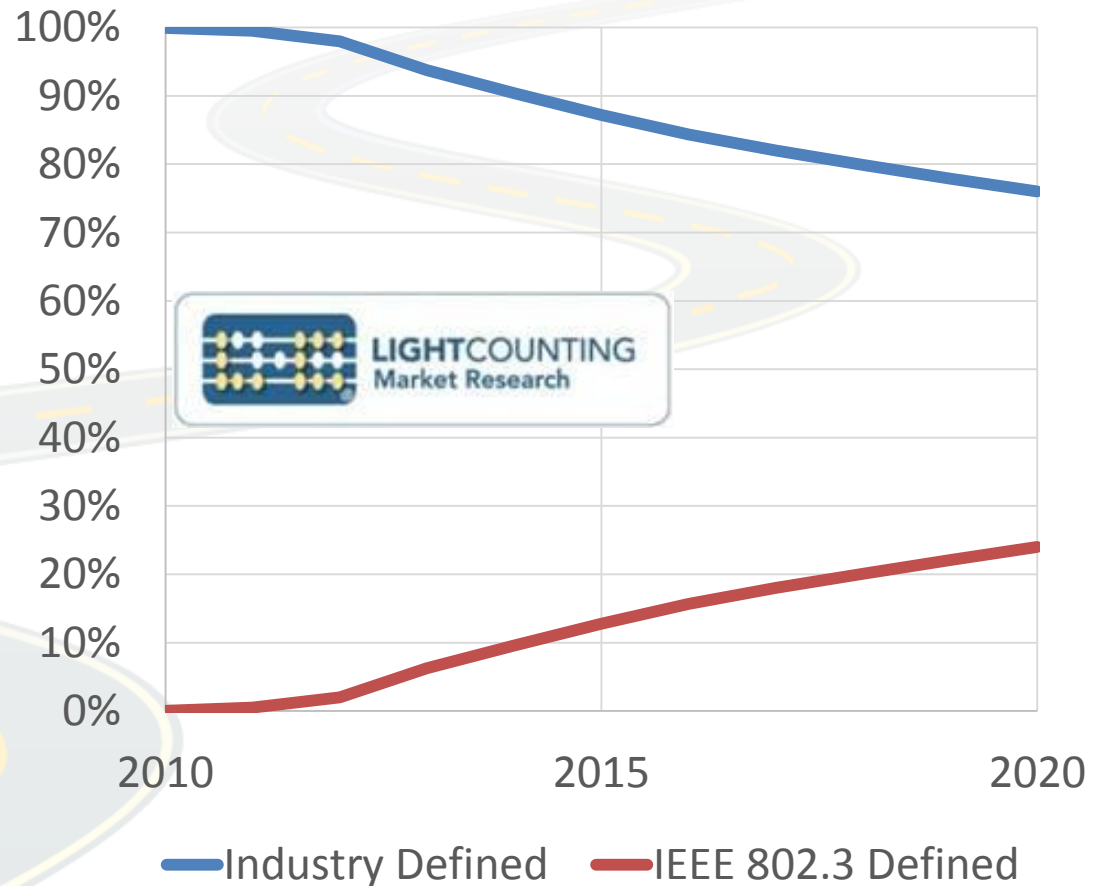

Trend #2: Non-Standardized Ethernet Optics

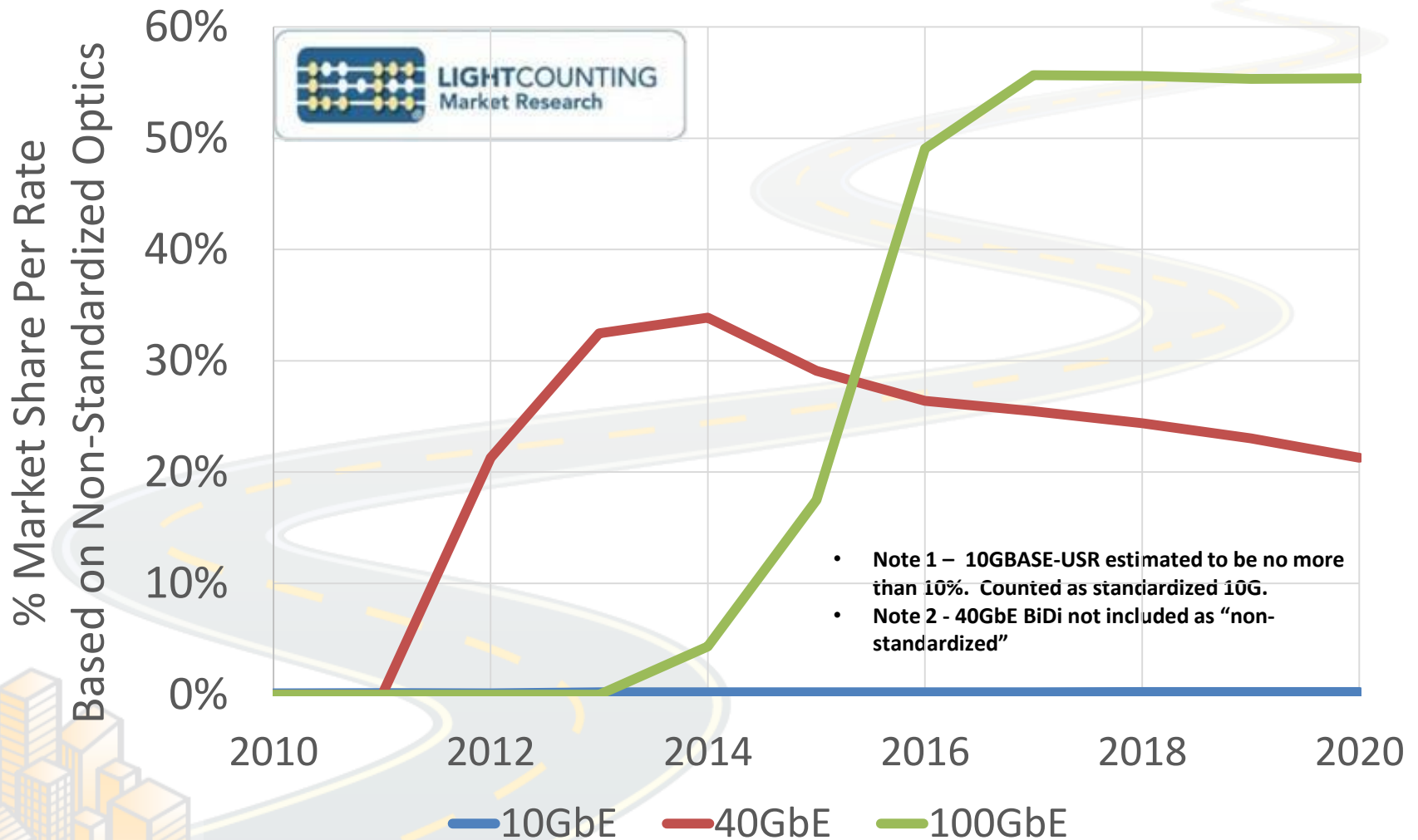

Trend #3: The New Ethernet Paradigm?

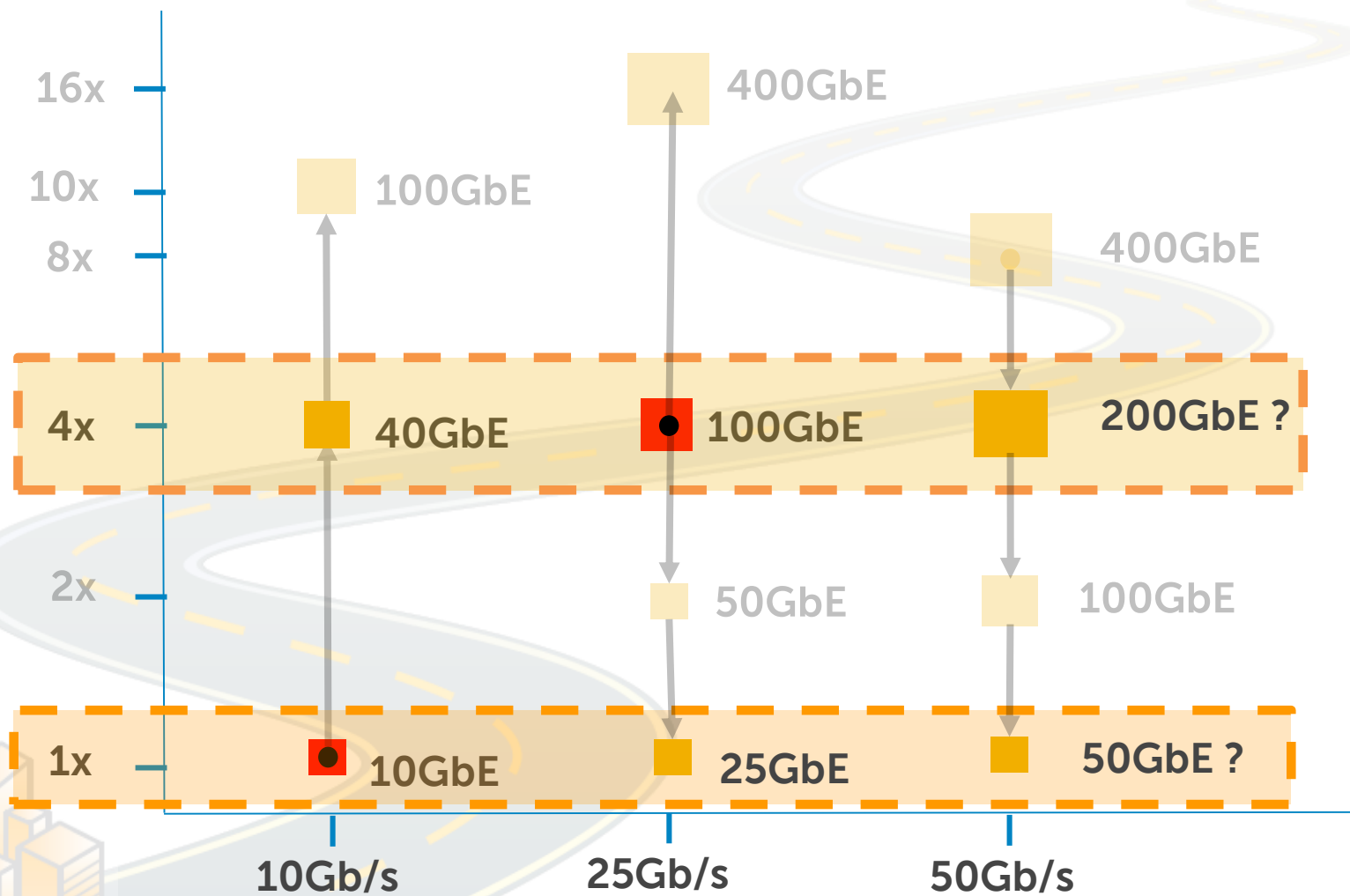

MOVING FORWARD



ethernet alliance

www.ethernetalliance.org

New Rates and Target Applications

Ethernet Rate	Wireless Access Points	Servers	Networking
1 Gb/s	✓	✓	
2.5 Gb/s	✓	?????	
5 Gb/s	✓	?????	
10 Gb/s	✓	✓	✓
25 Gb/s		✓	?????
40 Gb/s		✓	✓
50 Gb/s		?????	?????
100 Gb/s			✓
200 Gb/s			????
400 Gb/s			✓

Legacy of 10x?

Higher Speeds

The Ethernet Rate Roadmap

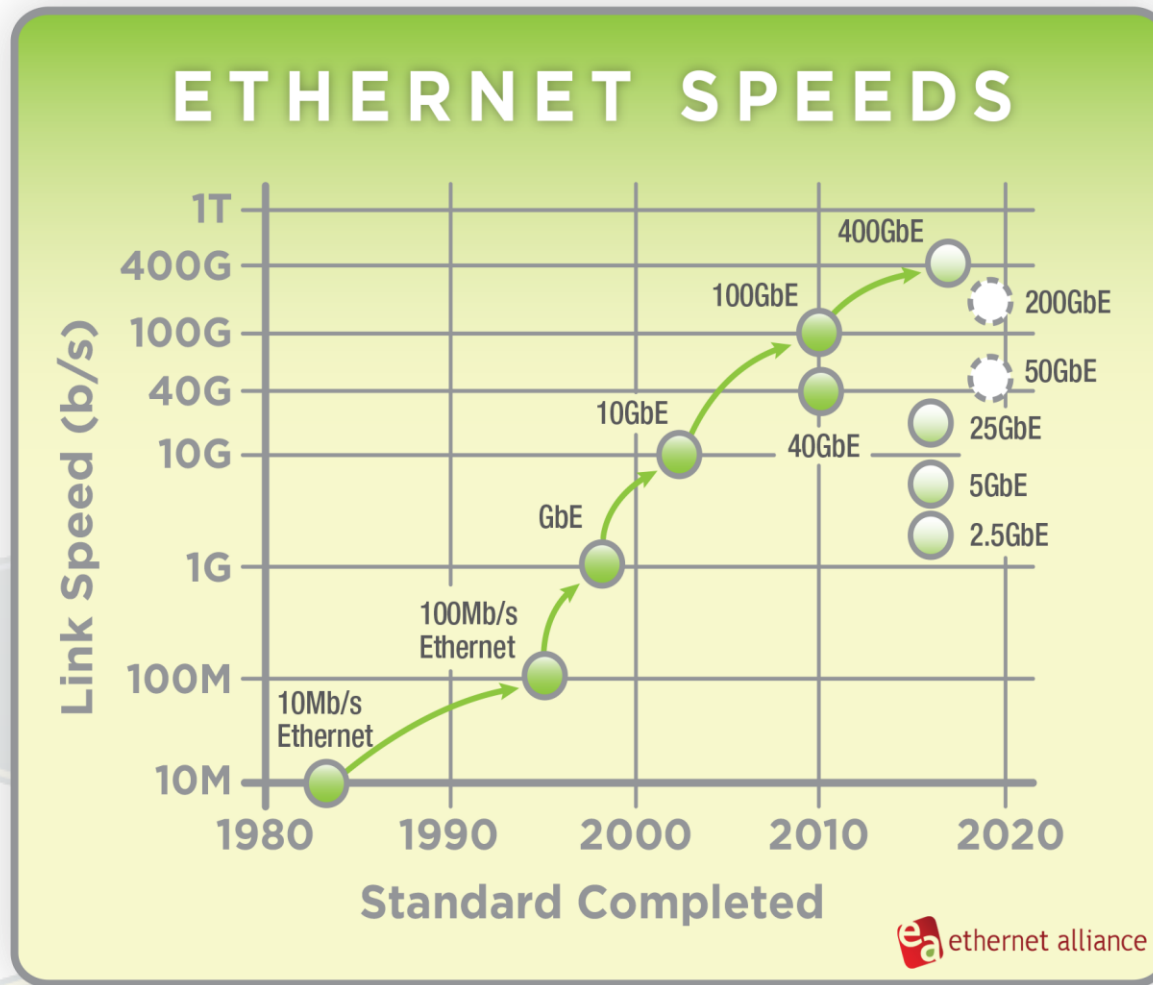

Check out the Ethernet Alliance “2015 Ethernet Roadmap” @ www.ethernetalliance.org/roadmap

Final Thought



We live in a
networked world of
diversity....

Where's
Your
Ethernet?

Thank You!



John D'Ambrosia

Chairman, Ethernet Alliance
Chief Ethernet Evangelist,
CTO Office, Dell

Email – jdambrosia@ieee.org

Follow me @jodam on Twitter

Follow me on [LinkedIn](#)

- Ethernet Alliance: visit www.ethernetalliance.org;
 -  Follow @EthernetAllianc on Twitter
 -  Join the Ethernet Alliance [LinkedIn group](#)
 -  Visit the Ethernet Alliance [Facebook page](#)
- IEEE P802.3bs 400GbE Task Force:
<http://www.ieee802.org/3/bs/index.html>